

# Contribution of Trough Concentration Data in the Evaluation of Multiple-Dose Pharmacokinetics for Drugs with Delayed Distributional Equilibrium and Long Half-Life

This article was published in the following Dove Press journal:  
*Drug Design, Development and Therapy*

Suein Choi <sup>1,2</sup>  
Sangil Jeon<sup>3</sup>  
Dong-Seok Yim <sup>1,2</sup>  
Seunghoon Han <sup>1,2</sup>

<sup>1</sup>Pharmacometrics Institute for Practical Education and Training (PIPET), College of Medicine, The Catholic University of Korea, Seoul, Korea; <sup>2</sup>Department of Pharmacology, College of Medicine, The Catholic University of Korea, Seoul, Korea; <sup>3</sup>Q-Fitter, Seoul, Korea

**Purpose:** The performance of “trough sampling before reaching steady-state” and “serial sampling beyond the interval between steady-state” in a multiple-dose pharmacokinetic evaluation was compared. Drugs with long half-lives, following multi-compartment pharmacokinetics, and whose distribution-related characteristics are less likely to be assessed within one dosing interval are focused.

**Patients and methods:** Amlodipine pharmacokinetic data were collected from a human pharmacology study performed in Seoul St. Mary’s Hospital (Seoul, Korea). Plasma concentration data until 144 hrs after a single administration was used. Nonlinear mixed-effects modeling was conducted to obtain the “true” model structure and pharmacokinetic parameter estimates. Then, stochastic simulation and estimation were performed using multiple-dose scenarios in various sampling strategies. Parameter accuracy and precision from each scenario were evaluated.

**Results:** A two-compartment model with first-order absorption followed by zero-order absorption with a lag time then first-order elimination was chosen as the final model and used in the stochastic simulation and estimation. In terms of parameter precision, the scenario incorporating data only within one dosing interval showed the worst results ( $V_p/F = 31.3\%$ ,  $Q/F = 64.3\%$ ). Some scenarios including early trough samples yielded comparable outcomes ( $V_p/F = 18.4\%$ ,  $Q/F = 32.1\%$ ) to the extended full-PK sampling scenario ( $V_p/F = 15.9\%$ ,  $Q/F = 30.3\%$ ), which was the best case. The quality of distribution-related parameters was the major difference between scenarios.

**Conclusion:** In multiple-dose studies on drugs with delayed distributional equilibrium, information from a few trough samples can augment the limit of serial sampling within the dosing interval for parameter estimation. With informative trough samples, extended hospitalization for serial sampling (until 3–5 half-lives after the last dose), which is particularly problematic for long half-life drugs, may be avoided. Trough samples obtained at the beginning of the repeated dose were more effective for mixed-effects modeling.

**Keywords:** pharmacokinetics, trough sampling, multiple-dose, stochastic simulation and estimation, NONMEM

Correspondence: Seunghoon Han  
Department of Pharmacology, College of  
Medicine, The Catholic University of  
Korea, 222, Banpo-Daero, Seocho-Gu,  
Seoul 06591, Korea  
Tel +82 2 2258 7326  
Fax +82 2 2258 7876  
Email waystolove@catholic.ac.kr

## Introduction

During drug development, a full pharmacokinetic (PK) study in the context of repeated dosing is one of the essential elements. The main goal of these studies is to identify the highest and lowest concentrations of the drug that form under steady-state

conditions, which can be used to determine not only the accumulation index but also the overall PK properties. However, for drugs with long half-lives (>24 hrs),<sup>1</sup> a repeated-dose study is not simple. It is generally accepted that steady-state achievement requires repeated doses over 5 or more half-lives, and PK evaluation requires blood sampling over at least 3–5 half-lives after the final dose.<sup>1,2</sup> To ensure reliability, the study subjects are often required to take medication for 3–5 days or more and may be hospitalized without medication for an additional length of time. This can be especially problematic in studies involving patients. Because there are insufficient concentration data available for a PK evaluation within the standard dosing interval (usually less than a day), the drug may be discontinued for a full-PK study, which compromises the therapeutic benefit, or only the data within the standard dosing interval are sometimes used for the recommended treatment. Various methods for solving these problems are being studied, which is reflected in the guidance documents provided by regulatory authorities.<sup>1,2</sup>

Trough samples are an excellent method that complements an insufficient steady-state full-PK study.<sup>3,4</sup> Trough samples, which are taken before reaching the steady-state, show how the drug accumulates over time, providing valuable information about drug disposition. For example, if the elimination rate constants estimated from concentration data over a short period following steady-state dosing do not coincide with changes in trough concentration, this means that the drug does not follow a simple 1-compartment model. Therefore, it can be expected that an informative trough sample and a full-PK sample during the standard dosing interval could be used together to evaluate the disposition characteristics of the drug properly. Additionally, trough samples are particularly helpful for drugs with more than two-compartment PK and those showing delayed distributional characteristics. For these drugs, the evaluation of the elimination property may not be appropriately achieved only with the data obtained within a dosing interval. Multiple-dose studies on such drugs often utilize trough sampling strategies in addition to steady-state sampling.<sup>5,6</sup>

In this study, amlodipine (half-life 40–50 hrs, time to distributional equilibrium 16–24 hrs post-dose) was selected as an example drug because it satisfies the conditions mentioned earlier. After generating a large number of virtual datasets using PK parameters obtained from actual data, PK parameters were estimated by applying different sampling strategies in various scenarios. We then compared the performance of "trough sampling before

reaching steady-state" and "extended sampling beyond the dosing interval" in a multiple-dose PK evaluation.

## Materials and Methods

### Actual Data

Amlodipine PK data were collected from a human pharmacology study performed in Seoul St. Mary's Hospital, Seoul, Korea (NCT02205151 at clinicaltrials.gov). The trial was performed in accordance with relevant guidelines, regulations, and the Declaration of Helsinki and was approved by the Institutional Review Board (IRB) of Seoul St. Mary's Hospital (Approval number: KC14MDSF0427). All participants provided written informed consent (n = 30). A single dose of a 5-mg amlodipine tablet was administered orally with 150 mL of water at 9:00 am after overnight fasting. Amlodipine was co-administered with fimasartan; however, no PK interaction was noted between two drugs,<sup>7</sup> indicating that the amlodipine PK was not affected by concomitant use of fimasartan. Plasma samples of amlodipine were collected before and at 1, 2, 3, 4, 6, 8, 12, 24, 48, 72, 96, and 144 hrs after the administration. Liquid chromatography coupled with tandem mass spectrometry (HPLC-MS/MS) was used to determine amlodipine concentrations with a validated working range of 0.2 ng/mL (the lower limit of quantification, LLOQ) to 32.0 ng/mL. The plasma concentration versus time profiles are shown in Figure 1. No further clinical trial data will be shared regarding this manuscript since this is not a report on the corresponding clinical trial.

### Population PK Modeling

Nonlinear mixed-effects modeling was conducted to obtain the "true" model structure and PK parameter estimates using NONMEM software, version 7.4 (Icon Development Solutions, Ellicott City, MD, USA). The first-order conditional estimation method with interaction (FOCE-I) was used whenever applicable. During model development, the significance of model improvement was evaluated using a likelihood-ratio test (LRT) for the objective function values (OFVs). In the nested models, the result was considered statistically significant if the OFV decreased more than 3.84 ( $P$ -value < 0.05, degree of freedom (df) = 1) or 5.99 ( $p$ -value < 0.05,  $df$  = 2). The degrees of freedom were defined as the absolute difference in the numbers of parameters compared in the two subsequent models. In the case of non-nested models, the Akaike information criteria (AIC) value was used to select the

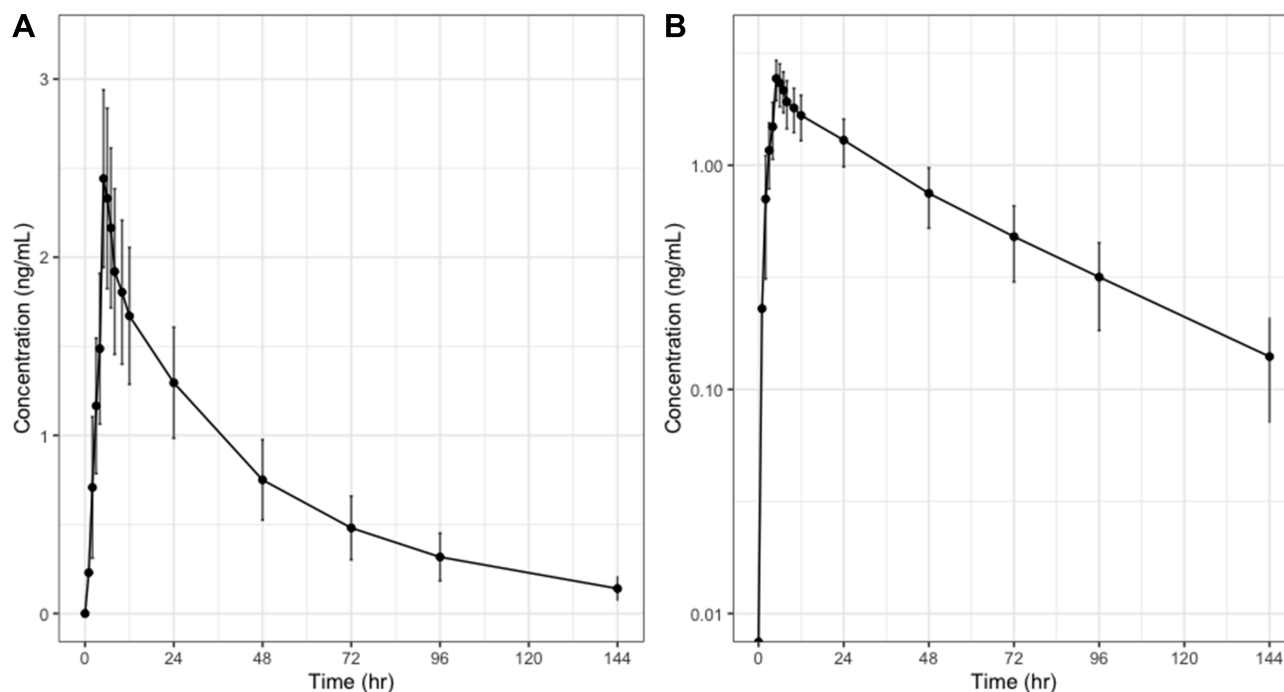

**Figure 1** Observed mean plasma concentration versus time profiles of single-dose amlodipine 5 mg using linear (A) or semilogarithmic (B) scales. The error bars represent the standard deviation.

model that best described the data. The major diagnostic methods used were visual inspection of various diagnostic plots (goodness-of-fit [GOF] plot) and a visual predictive check (VPC) for the final model. R software, version 3.5.1. (R Foundation for Statistical Computing, Vienna, Austria) were utilized for data preparation, graphical analysis, model diagnostics, and statistical summaries.

Based on the literatures on amlodipine PK, a two-compartment model with first-order absorption was adopted initially.<sup>8,9</sup> Various absorption (e.g., zero-order absorption, lag time, Weibull-type absorption, and dual absorption) and disposition structures (e.g., one-compartment model and three-compartment model) were tried as needed. Each PK parameter was assumed to follow a log-normal distribution and is described as

$$P_i = P_{TV} \times \exp(\eta_i),$$

where  $P_i$  is the individual parameter for the  $i$ th individual,  $P_{TV}$  is the typical value of the model parameter for the population, and  $\eta_i$  is the between-subject random effect, which follows a normal distribution with a mean of 0 and variance of  $\omega_i^2$  and accounts for the  $i$ -th individual's deviation from the typical value ( $P_{TV}$ ). An additive, a proportional, and a combined model were all evaluated.

## Sampling Scenarios

Although the PK model was developed from the data obtained from a single-dose study, we could assume that the PK structure and parameter estimates could be extrapolated in a multiple-dose setting (daily dosing) based upon reports showing no significant differences in the PK properties of amlodipine between single-dose and multiple-dose studies.<sup>10,11</sup> Thus, using the PK structure and parameters estimates from the final model, various simulation datasets for 7-consecutive-day dosing could be created by only altering the sampling times.

The sampling times were selected in consideration of the feasibility for actual multiple-dose trials. For all scenarios, data corresponding to a standard dosing interval full-PK sampling (pre-dose, 0.33, 0.66, 1, 1.5, 2, 3, 4, 5, 6, 7, 8, 10, 12, and 24 hrs post the last dose) were generated. In scenarios with no trough data, data points at either 48 hrs (termed 0s48) or 72, 96, and 144 hrs (until 3–4 half-lives, termed 0s144) post-dose were added. When generating the data for scenarios with trough information, the limit in the number of outpatient visits (1–2 times during the multiple-dose period) was taken into consideration. Thus, one-trough-sample scenarios (1sX) were only allowed to have one pre-dose data point on one of the dosing days (Day 2–6). Two-trough-sample scenarios (2sX) were generated in a similar way. Details of the sampling scenarios are presented in Table 1.

## Statistical Methods for Stochastic Simulation and Estimation

Stochastic simulation and estimation (SSE) were performed using the Perl-speaks-NONMEM toolkit (PsN) version 4.9.0 (Mats Karlsson, Rikard Nordgren, Svetlana Freiberga, Sebastian Ueckert and Gunnar Yngman, Uppsala, Sweden) to evaluate the adequacy of scenarios with different sampling strategies for predicting PK parameters.<sup>12</sup> In this study, 500 datasets consisting of 30 subjects each were simulated for each scenario using the final PK model. Subsequently, the population PK parameters were estimated for each of the dataset using the first-order conditional estimation with interaction (FOCE-I) method in NONMEM. For each scenario, the relative estimation error and the relative bias in estimating PK parameters were calculated using Equations (1) and (2), and relative root mean square errors (RMSE) are obtained using Equation (3)

$$\text{Relative estimation error (\%)} = 100 \times \frac{E_i - A}{A} \quad (1)$$

$$\text{Relative bias (\%)} = 100 \times \frac{1}{A \times N} \sum_{i=1}^N (E_i - A) \quad (2)$$

$$\text{Relative root mean square error (\%)} = 100 \times \frac{1}{A} \sqrt{\frac{1}{N} \sum_{i=1}^N (E_i - A)^2} \quad (3)$$

where  $E_i$  is the estimated PK parameters of  $i$ -th data set,  $A$  is the true PK parameter from the final model, and  $N$  is the number of datasets with successful estimation in each scenario.

The scenario where estimated PK parameters were least biased and had minimal standard error was selected based on the RMSE value, and its sampling strategy was considered to be appropriate for the prediction of PK parameters. Because the absorption PK parameters were expected to be well estimated from the common data included in all scenarios (dense samples during absorption period within one dosing interval), they were excluded from the comparison.

## Results

### Amlodipine PK Model

The amlodipine PK data were best described by two-compartment models with first-order absorption followed by zero-order absorption with a lag time then first-order elimination (Figure 2). Population PK parameter estimates were derived from the structural model as follows: oral clearance ( $CL/F$ ) 36.4 L/hr, central volume ( $V_c/F$ ) 1,150 L, intercompartmental clearance ( $Q/F$ ) 118 L/hr, peripheral volume ( $V_p/F$ ) 910 L, absorption rate constant ( $k_a$ ) 0.563/hr, fraction absorbed through first-order absorption ( $F_1$ ) 0.762, duration of zero-order absorption ( $D_2$ ) 2.36 hr, lag time for first-order absorption ( $ALAG_1$ ) 0.51 hr, and lag time for zero-order absorption ( $ALAG_2$ ) 3.85 hr. All parameter estimates including between subject variability are shown in Table 2. The summarized result of 1,000 bootstrap replicates in Table 2 shows that the mean parameter estimates from the bootstrap procedure were compared with the corresponding estimates derived from the final model. The goodness-of-fit plots of the final PK model presented in Figure 3 show that no specific evidence of model misspecification was found between individual weighted residuals (IWRES) and population prediction (PRED) or conditional weighted residuals (CWRES) and time, and there was good agreement between the observed data and individual prediction (IPRED).<sup>13</sup>

### Comparison of the Scenarios

Statistical evaluation was performed on the population PK parameters (fixed and random effects) estimated from each scenario, and the results are shown in Table 3. Also, the relative estimation errors are shown in the boxplot in Figure 4.

**Table 1** Comparison of Sampling Scenarios

Scenario No.	Trough Data (h)	PK Data Timepoints After Last Dose (h)
0s24	-	24-hr full sampling
0s48	-	24-hr full sampling + 48
0s144	-	24-hr full sampling + 48, 72, 96, and 144
1s1	24	24-hr full sampling
1s2	48	24-hr full sampling
1s3	72	24-hr full sampling
1s4	96	24-hr full sampling
1s5	120	24-hr full sampling
2s1	24, 48	24-hr full sampling
2s2	24, 72	24-hr full sampling
2s3	24, 96	24-hr full sampling
2s4	24, 120	24-hr full sampling
2s5	48, 72	24-hr full sampling
2s6	48, 96	24-hr full sampling
2s7	48, 120	24-hr full sampling
2s8	72, 96	24-hr full sampling
2s9	72, 120	24-hr full sampling
2s10	96, 120	24-hr full sampling

**Notes:** 24-hr full sampling was performed at 0, 0.33, 0.66, 1, 1.5, 2, 3, 4, 5, 6, 7, 8, 10, 12, and 24 hrs.

**Abbreviation:** PK, pharmacokinetic.

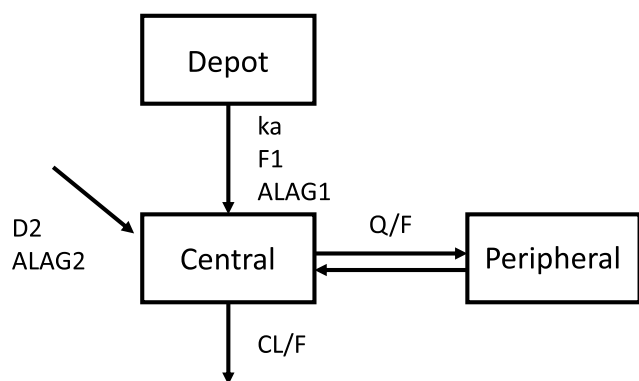

**Figure 2** Amlodipine PK model.

**Abbreviations:**  $CL/F$ , apparent oral clearance;  $V_c/F$ , central volume;  $V_p/F$ , peripheral volume;  $Q/F$ , intercompartmental clearance;  $ALAG$ , lag time;  $F_1$ , fraction of dose absorbed in first-order absorption;  $k_a$ , absorption rate constant;  $D_2$ , duration of zero-order absorption.

In terms of the RMSE%, the scenario using data obtained only within the dosing interval (0s24) showed the worst results in the precision of parameter estimates ( $CL/F = 9.23\%$ ,  $V_c/F = 20.6\%$ ,  $V_p/F = 313\%$ ,  $Q/F = 64.3\%$ ,  $BSV(CL/F) = 33.9\%$ ,  $BSV(V_c/F) = 108\%$ ,  $BSV(V_p/F) = 2,550\%$ ). The scenario using data from the extended period (~144 hr post-dose, 0s144) showed the best result as expected ( $CL/F = 4.63\%$ ,

$V_c/F = 14.6\%$ ,  $V_p/F = 15.9\%$ ,  $Q/F = 30.3\%$ ,  $BSV(CL/F) = 23.1\%$ ,  $BSV(V_c/F) = 47.8\%$ ,  $BSV(V_p/F) = 52.9\%$ ). The two-trough-sample scenario with 24-hr and 48-hr data (2s1) yielded the comparable results in the extended period scenario, and RMSE% of both population PK parameters and their between-subject variability parameters was acceptable ( $CL/F = 4.72\%$ ,  $V_c/F = 16.0\%$ ,  $V_p/F = 18.4\%$ ,  $Q/F = 32.1\%$ ,  $BSV(CL/F) = 22.9\%$ ,  $BSV(V_c/F) = 65.9\%$ ,  $BSV(V_p/F) = 78.0\%$ ). For the one-trough-sample scenario using concentration data at 24 hrs (1s1) and two-trough-sample scenario using concentration data at 24-hr and 72-hr, the RMSE% was also acceptable. Acceptance criteria were defined as <120% of RMSE% in the extended period scenario (0s144) for population PK parameters, and <150% for their variability parameters. The quality of distribution-related parameters was the major differences between scenarios. The detailed results from each scenario are shown in Table 3.

## Multiple-Dose PK Simulation Using the Best Parameter Estimates

A multiple-dose PK was simulated to see the predictive performance of the results from trough sample scenario

**Table 2** Parameter Estimates of Final PK Model

Parameter	Description	Estimate	%RSE <sup>a</sup>	Bootstrap Median (95% CI) <sup>b</sup>
<b>Population parameters</b>				
$CL/F$ (L/h)	Apparent oral clearance	36.4	3.30	36.5 (34.3–38.5)
$V_c/F$ (L)	Apparent central volume	1,150	5.89	1139 (998–1270)
$Q/F$ (L/h)	Apparent intercompartmental clearance	118	13.0	119 (91.8–154)
$V_p/F$ (L)	Apparent peripheral volume	910	7.33	922 (791–1049)
$k_a$ (/h)	Absorption rate constant	0.563	10.6	0.562 (0.459–0.691)
$F_1$	Fraction absorbed in first absorption	0.762	4.00	0.755 (0.717–0.802)
$D_2$ (h)	Duration of zero-order absorption	2.36	4.58	2.35 (0.0328–2.73)
$ALAG_1$ (h)	Lag time of first-order absorption	0.51	4.22	0.515 (0.461–0.576)
$ALAG_2$ (h)	Lag time of zero-order absorption	3.85	4.81	3.85 (3.63–4.00)
<b>Between-subject variability</b>				
$\omega_{CL/F}$	Interindividual variability of $CL/F$	0.0781	17.6	0.0771 (0.0528–0.104)
$\omega_{V_c/F}$	Interindividual variability of $V_c/F$	0.0714	19.4	0.0713 (0.0469–0.103)
$\omega_{V_p/F}$	Interindividual variability of $V_p/F$	0.0481	27.5	0.0474 (0.0216–0.0750)
$\omega_{k_a}$	Interindividual variability of $k_a$	0.308	18.1	0.299 (0.202–0.418)
$\omega_{ALAG_1}$	Interindividual variability of $ALAG_1$	0.0555	34.7	0.0512 (0.0224–0.0985)
$\omega_{F_1}$	Interindividual variability of $F_1$	0.0178	36.6	0.0150 (0.00480–0.0253)
<b>Residual error</b>				
$\sigma_{prop}$	Proportional error	0.118	7.69	0.118 (0.104–0.136)

**Notes:** <sup>a</sup>Relative standard error was estimated using the \$COV function in NONMEM, <sup>b</sup>95% confidence interval (CI) was estimated by applying the final PK model to 1000 resamples.

**Abbreviations:** RSE, relative standard error; CI, confidence interval; CV, coefficient of variation.

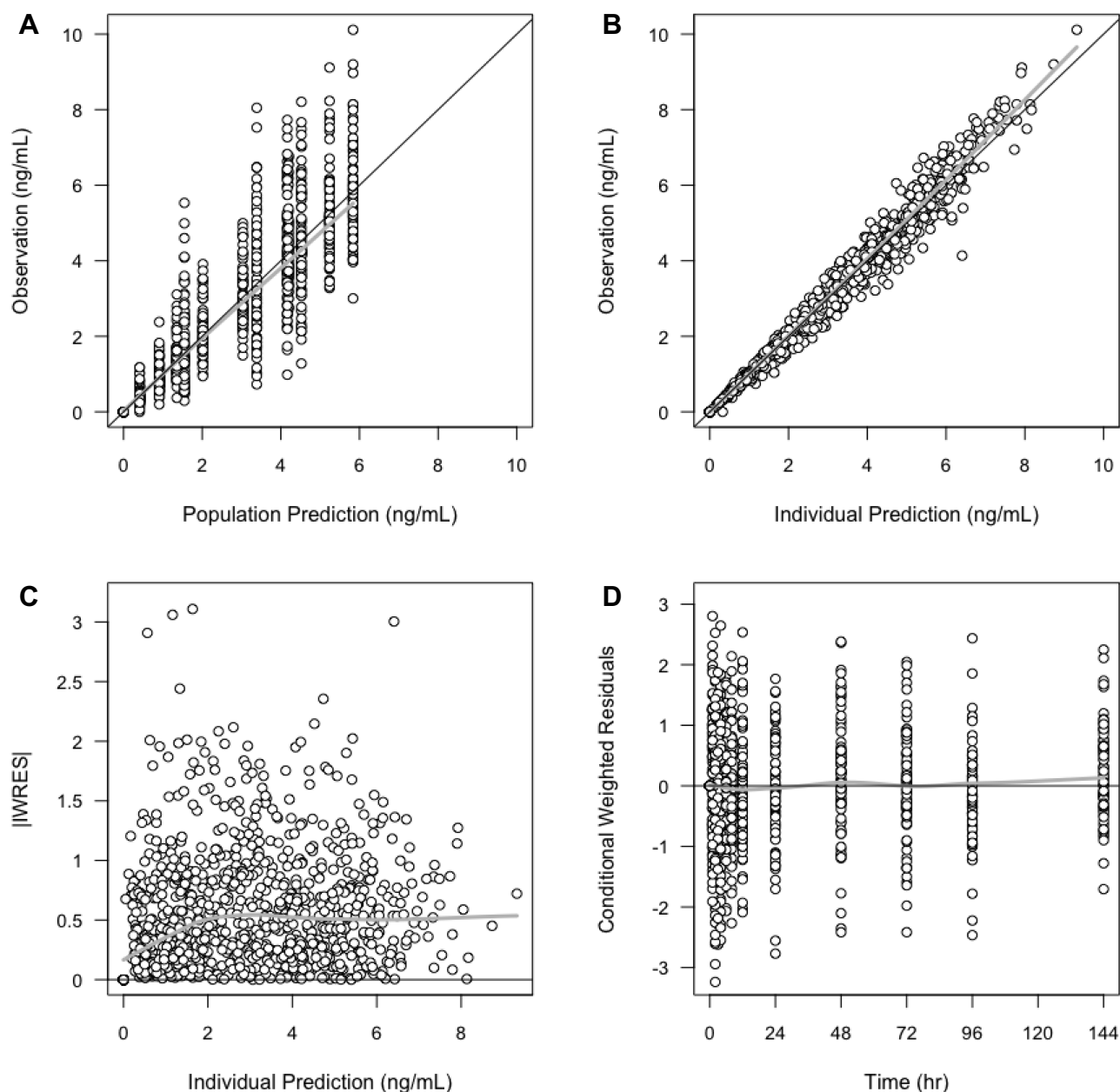

**Figure 3** Goodness-of-fit plots of the final PK model for population prediction versus observation (A), individual prediction versus observation (B), individual prediction versus the absolute value of individual weight residuals (IWRES), (C), and time versus conditional weighted residuals (CWRES), (D). The black solid  $y=x$  and  $y=0$  lines are included for reference. The bold grey lines are loess (local regression smoother) trend lines, and the circles indicate observational data.

of the least RMSE% value ( $2s_1$ ). The plasma concentration versus time profile was generated for one standard dosing interval (24 hr) after the seventh dose (144 hr after the first dose) of 5 mg. Virtual observations were derived from the true PK parameters at 144, 144.33, 144.66, 145, 145.5, 146, 147, 148, 149, 150, 151, 152, 154, 156, and 168 hrs and compared to the simulated time-concentration profile. The median values and prediction interval of simulated concentration throughout the

planned time period were well matched with the virtual observations (Figure 5).

## Discussion

In this study, we focused on drugs with long half-lives, following a two-compartment PK, and whose distribution-related characteristics are less likely to be observed within one dosing interval. We evaluated how trough concentration measured during repeated administration of these

**Table 3** Statistical Evaluation of Various Scenarios for Amlodipine PK Parameter Prediction

Scenario No.	CL/F		V <sub>c</sub> /F		V <sub>p</sub> /F		Q/F		BSV (CL/F)		BSV (V <sub>c</sub> /F)		BSV (V <sub>p</sub> /F)	
	Acceptance	RMSE% (Relative bias%)	Acceptance	RMSE% (Relative bias%)	Acceptance	RMSE% (Relative bias%)	Acceptance	RMSE% (Relative bias%)	Acceptance	RMSE% (Relative bias%)	Acceptance	RMSE% (Relative bias%)	Acceptance	RMSE% (Relative bias%)
0s24	X	9.23 (-1.65)	X	20.6 (-4.93)	X	313 (38.3)	X	64.3 (24.8)	O	33.9 (2.39)	X	108 (17.6)	X	2550 (204)
0s48	O	5.35 (-0.15)	O	17.4 (-5.03)	X	27.1 (10.4)	X	58.0 (20.9)	O	23.2 (-2.53)	X	80.1 (16.6)	X	233 (49.0)
0s144	O	4.63 (0.32)	O	14.6 (-0.54)	O	15.9 (1.48)	O	30.3 (7.08)	O	23.1 (-0.24)	O	47.8 (4.25)	O	52.9 (-5.50)
1s1	O	4.54 (0.49)	O	16.1 (-1.74)	O	18.6 (7.06)	O	31.9 (7.33)	O	21.0 (-1.15)	X	74.0 (9.64)	X	108 (-2.36)
1s2	O	5.03 (0.35)	O	16.8 (-1.40)	X	20.6 (6.77)	O	36.2 (5.73)	O	22.9 (-4.31)	X	76.8 (8.39)	X	234 (18.1)
1s3	O	4.89 (0.59)	O	16.5 (-1.31)	X	21.4 (6.15)	O	35.0 (5.12)	O	23.0 (-2.91)	X	79.9 (5.92)	X	141 (8.21)
1s4	O	5.54 (0.83)	O	16.8 (-1.88)	X	24.8 (6.31)	X	43.4 (10.6)	O	24.2 (-1.17)	O	67.8 (3.29)	X	289 (56.8)
1s5	X	6.50 (-0.60)	X	19.6 (-3.36)	X	40.9 (14.4)	X	53.4 (17.1)	O	30.2 (-2.03)	X	79.1 (12.8)	X	268 (45.5)
2s1	O	4.72 (0.25)	O	16.0 (-1.44)	O	18.4 (6.13)	O	32.1 (6.93)	O	22.9 (-1.75)	O	65.9 (7.97)	O	78.0 (-3.29)
2s2	O	4.54 (0.80)	O	15.6 (-0.42)	O	18.7 (5.9)	O	31.0 (3.72)	O	21.3 (-1.05)	O	53.4 (2.26)	X	124 (4.28)
2s3	O	4.75 (0.23)	O	16.7 (-0.25)	X	19.9 (6.22)	O	35.0 (3.99)	O	22.9 (-2.32)	O	69.2 (6.50)	X	112 (4.31)
2s4	O	4.93 (0.40)	O	16.6 (-0.92)	X	19.1 (6.23)	O	33.9 (6.25)	O	23.6 (-3.51)	O	60.9 (8.60)	X	94.2 (1.85)
2s5	O	4.83 (0.88)	O	16.0 (-1.82)	X	19.5 (6.22)	O	32.8 (7.86)	O	22.9 (-3.06)	O	65.7 (3.72)	X	137 (7.54)
2s6	O	4.95 (0.40)	O	16.2 (-0.50)	X	20.3 (5.17)	O	32.5 (4.74)	O	22.2 (-2.06)	O	60.9 (5.60)	X	122 (4.69)
2s7	O	4.83 (0.52)	O	15.7 (-0.05)	X	19.6 (4.59)	O	32.2 (3.10)	O	22.0 (-2.37)	O	56.6 (5.96)	X	171 (14.5)
2s8	O	4.69 (0.58)	O	16.4 (-1.21)	X	20.5 (5.08)	X	36.8 (7.34)	O	24.7 (-3.52)	O	68.7 (4.20)	X	223(24.5)
2s9	O	4.71 (0.60)	X	17.7 (-1.60)	X	22.8 (5.64)	X	38.4 (6.52)	O	23.8 (-3.66)	X	78.5 (10.6)	X	212(31.3)
2s10	O	5.40 (0.54)	X	18.6 (-3.05)	X	27.7 (9.28)	X	43.2 (12.1)	O	24.4 (-4.00)	X	84.2 (14.6)	X	214(35.2)

**Notes:** The circle mark indicates that the corresponding RMSE% is acceptable (Acceptance criteria: <120% of RMSE% from the standard procedure (0s144) for the population PK parameter prediction, whereas <150% for the variability parameter prediction).

**Abbreviations:** RMSE, Relative root mean square error; CL/F, apparent oral clearance; V<sub>c</sub>/F, central volume; V<sub>p</sub>/F, peripheral volume; Q/F, intercompartmental clearance; BSV, between subject variability.

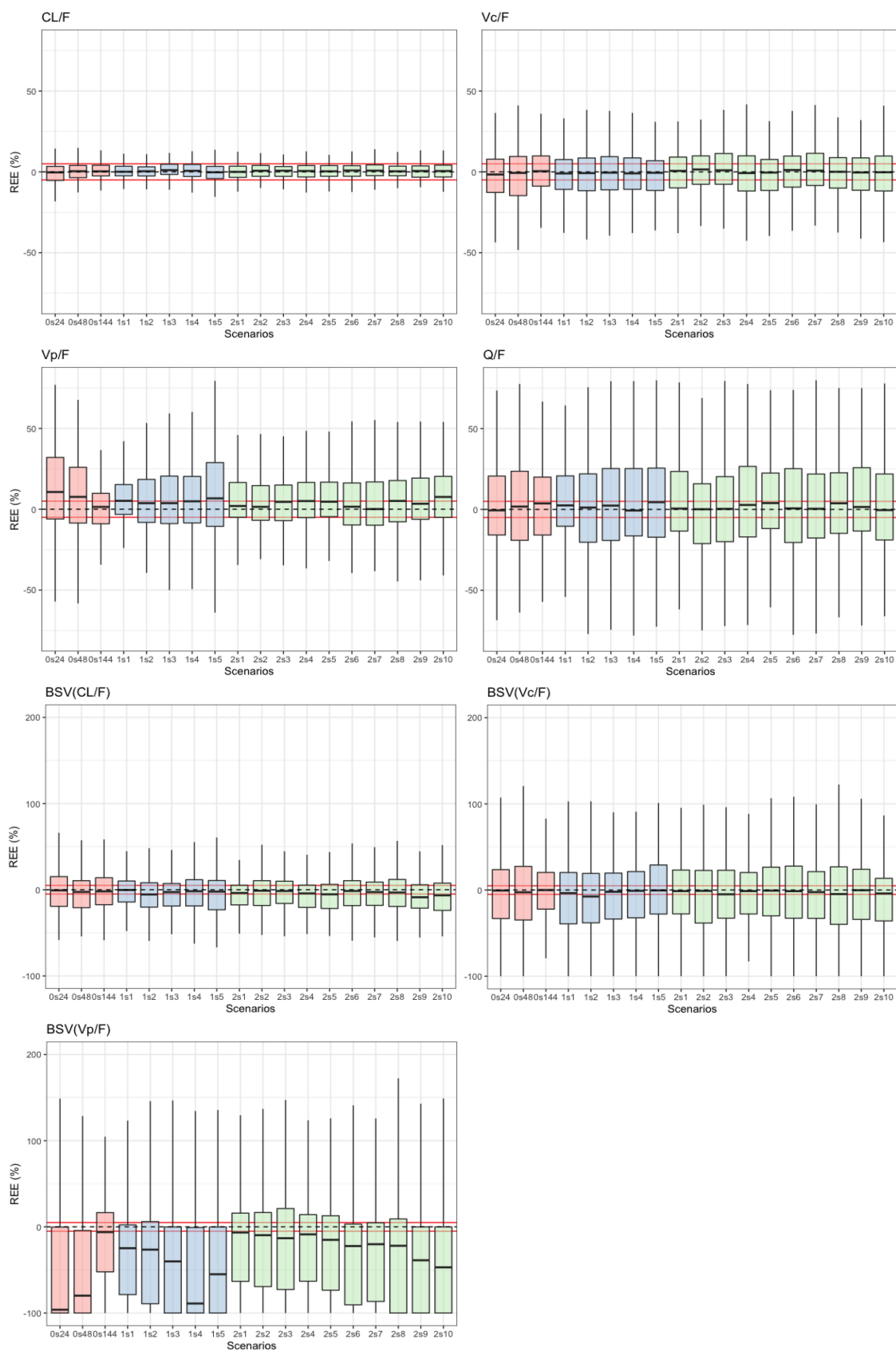

**Figure 4** Boxplots of the relative estimation error of parameter estimates in various scenarios. Pink boxes are from zero-trough-sampling scenarios, blue from one-trough-sampling scenarios, and green from two-trough-sampling scenarios. The red lines indicate the acceptable error margin (<5%).

**Abbreviations:** CL/F, apparent oral clearance;  $V_c/F$ , central volume;  $V_p/F$ , peripheral volume; Q/F, intercompartmental clearance; BSV, between subject variability.

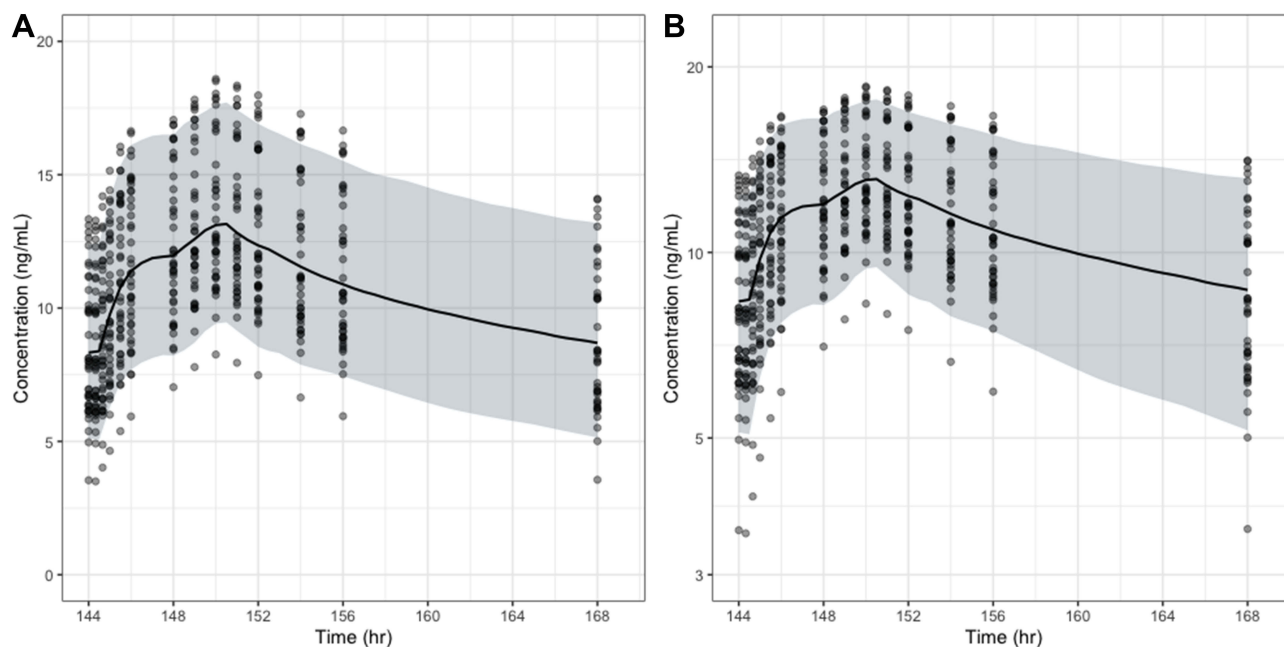

**Figure 5** Predicted plasma concentration versus time profiles using linear (A) and semilogarithmic (B) scales. The black solid line represents the median curve for the simulation, and the gray area represents the 90% confidence interval for the simulation. The black circles indicate observational data, and the grey area indicates prediction interval.

drugs could contribute to PK evaluation through various simulations. The findings were considered feasible based on existing knowledge of PK, and some clues for practical applications in multiple-dose PK studies are reported.

For drugs with long half-lives, the relevant regulations allow the use of results from PK sampling up to three half-lives after the final dose as the full-PK study.<sup>2</sup> The maximum sampling duration for the full-PK scenarios (0sX) in this study was determined accordingly. For these drugs, this approach is considered feasible because hospitalization or sampling over more extended periods is not practical. The scenario with the best results was when sampling was performed for the longest time (until 144 hrs after the last dose, 0s144). However, in some scenarios where full-PK sampling was not performed, comparable results were obtained. Even in scenarios where sampling was performed for more than one dosing interval, insufficient sampling duration (0s48) yielded poor results. This shows the possibility of trough sampling at a sufficiently informative time point replacing the extended full-PK study. Therefore, it may be reasonable to design an actual repeated dose study with an appropriate trough sampling plan to avoid excessively lengthy hospitalization and dosing suspension.

Parameters related to the central compartment ( $CL/F$ ,  $V_c/F$ ) were relatively well estimated in all scenarios, including that with observations only during a single dosing interval (0s24).

This implies that the information obtained by sampling within the dosing interval is sufficient to estimate such parameters. Since there were actual observations to calculate the area under the curve during a single dosing interval ( $AUC_\tau$ ), it would have been possible to estimate the  $CL/F$ . Also, it can be inferred that  $V_c/F$  was estimable since the values for trough concentration immediately before the last dose and the maximum plasma concentration ( $C_{max,ss}$ ) of the dose were observed. The parameters that caused the problem with accuracy and precision were those related to distribution of drugs. It is difficult to accurately estimate these parameters without an appropriate trough sample or full-PK sample. However, this seems to be because we focused on a situation where it is difficult to evaluate the distribution characteristics within one dose interval.

In scenarios where trough samples were obtained at a relatively early time (1s1 or 2s1), distribution-related parameters were relatively well estimated. These scenarios produced better results than those with an insufficient number of full-PK samples (0s48). When a drug following the 2-compartment PK model is repeatedly administered, changes in drug concentration up to steady-state are expressed as the sum of exponential terms (asymptotic).<sup>14,15</sup> Accordingly, the difference in concentration accumulation pattern according to the PK parameter values is more significant at the beginning of the

repeated administration than in the period near the steady-state. In practical terms, it would be desirable to schedule a limited number of outpatient visits to obtain a trough sample as soon as possible after the start of repeated administration.

As with the fixed-effect parameter mentioned earlier, the BSV parameter showed similar results for  $CL/F$  and  $V_d/F$  in all scenarios. This shows that the amount of information about the parameter was similar regardless of the sampling strategy. However, the results of  $Q/F$ , the only distribution parameter that allowed estimation of BSV, showed a big difference across scenarios. Only the scenarios with two trough data, including 24 hr sample, yielded a parameter estimate with comparable quality to that from 0s144. In other words, in the situation where the most informative timepoint sample is obtained, at least one additional trough sample should be obtained to estimate the individual PK difference accurately. In scenarios with inaccurate estimates, the BSV value appears to be distributed on the smaller side of the true value. This is because of the feature of NONMEM that arbitrarily fixes the BSV value to a small value when the parameter is inestimable or has no contribution to the model.<sup>16,17</sup> These results were frequently observed even in ‘minimization successful’ runs.

## Conclusion

Trough sampling contributes to estimation of the PK parameter in drugs for which it is difficult to assess distribution-related characteristics only by sampling during one dosing interval. Particularly, trough sampling may have more significant advantages in drugs with long half-lives by avoiding extended hospitalization (until 3–5 half-life after the last dose). This was shown from the comparable quality of parameter estimates with the best trough samples and those with extended full-PK samples. In mixed-effects modeling involving between-subject variabilities, the trough samples at the beginning of the repeated dose were better, and at least two trough samples are recommended. The overall results of this study can also be applied to the process of drug development. When a new drug candidate shows delayed distributional equilibrium and long half-life in a single-dose study, trough sampling instead of extended full-PK sampling should be considered to reduce procedural burden and subject discomfort.

## Acknowledgment

This work was supported by the National Research Foundation of Korea (NRF) grant funded by the Korea government (MIST) (No. 2017R1C1B5018160).

## Disclosure

The authors report no competing interest in this work.

## References

- Center for Drug Evaluation and Research (CDER) Guidance for industry: bioequivalence studies with pharmacokinetic endpoints for drug submitted under an ANDA. Food and Drug Administration; 2013. Available from: <https://www.fda.gov/media/87219/download>. Accessed December 31, 2019.
- European Medicines Agency. Guideline on the pharmacokinetic and clinical evaluation of modified release dosage forms. EMEA; 2014. Available from: [https://www.ema.europa.eu/en/documents/scientific-guideline/guideline-pharmacokinetic-clinical-evaluation-modified-release-dosage-forms\\_en.pdf](https://www.ema.europa.eu/en/documents/scientific-guideline/guideline-pharmacokinetic-clinical-evaluation-modified-release-dosage-forms_en.pdf). Accessed December 31, 2019.
- Ternant D, Passot C, Aubourg A, et al. Model-based therapeutic drug monitoring of infliximab using a single serum trough concentration. *Clin Pharmacokinet*. 2018;57(9):1173–1184. doi:10.1007/s40262-017-0621-6
- Wang Y, Chia YL, Nedelman J, Schran H, Mahon FX, Molimard M. A therapeutic drug monitoring algorithm for refining the imatinib trough level obtained at different sampling times. *Ther Drug Monit*. 2009;31(5):579–584. doi:10.1097/FTD.0b013e3181b2c8cf
- Schmitt C, Portron A, Jadidi S, Sarkar N, DiMarchi R. Pharmacodynamics, pharmacokinetics and safety of multiple ascending doses of the novel dual glucose-dependent insulinotropic polypeptide/glucagon-like peptide-1 agonist RG7697 in people with type 2 diabetes mellitus. *Diabetes Obes Metab*. 2017;19(10):1436–1445. doi:10.1111/dom.13024
- Lin CW, Dutta S, Asatryan A, et al. Pharmacokinetics, safety, and tolerability following single and multiple doses of pibrentasvir in a first-in-human study. *Clin Pharmacol Drug Dev*. 2018;7(1):44–52. doi:10.1002/cpdd.350
- Yi S, Kim TE, Yoon SH, et al. Pharmacokinetic interaction of fimasartan, a new angiotensin II receptor antagonist, with amlodipine in healthy volunteers. *J Cardiovasc Pharmacol*. 2011;57(6):682–689. doi:10.1097/FJC.0b013e31821795d0
- Heo YA, Holford N, Kim Y, Son M, Park K. Quantitative model for the blood pressure-lowering interaction of valsartan and amlodipine. *Br J Clin Pharmacol*. 2016;82(6):1557–1567. doi:10.1111/bcp.13082
- Kang WY, Seong SJ, Ohk B, et al. Pharmacokinetic and bioequivalence study of a telmisartan/S-amlodipine fixed-dose combination (CKD-828) formulation and coadministered telmisartan and S-amlodipine in healthy subjects. *Drug Des Devel Ther*. 2018; (12):545–553. doi:10.2147/DDDT.S156492
- Duan J, Chen J, Yin Q, et al. Pharmacokinetics of single and multiple oral doses of valsartan/amlodipine (80/5 mg) in healthy Chinese subjects. *Int J Clin Pharmacol Ther*. 2012;50(1):33–43. doi:10.5414/CP201601
- Norvasc® (amlodipine besylate) [package insert]. New York: Pfizer. 2011
- Karlsson M, Nordgren R, Freiberger S, Ueckert S, Yngman G. Perlspeaks-NONMEM (PsN) 4.9.0. SSE user’s guide. Uppsala, Sweden;2018. Available from: <https://uupharmacometrics.github.io/PsN/docs.html>. Accessed December 31, 2019.
- Hooker AC, Staatz CE, Karlsson MO. Conditional weighted residuals (CWRES): a model diagnostic for the FOCE method. *Pharm Res*. 2007;24(12):2187–2197. doi:10.1007/s11095-007-9361-x
- Han YR, Lee PI, Pang KS. Finding T<sub>max</sub> and C<sub>max</sub> in multicompartmental models. *Drug Metab Dispos*. 2018;46(11):1796–1804. doi:10.1124/dmd.118.082636

15. Fitzmaurice GM, Davidian M, Verbeke G, Molenberghs G. *Longitudinal Data Analysis*. Boca Raton: Chapman & Hall; 2008.
16. Savic RM, Karlsson MO. Importance of shrinkage in empirical bayes estimates for diagnostics: problems and solutions. *AAPS J*. 2009;11(3):558–569. doi:10.1208/s12248-009-9133-0
17. Xu XS, Yuan M, Karlsson MO, Dunne A, Nandy P, Vermeulen A. Shrinkage in nonlinear mixed-effects population models: quantification, influencing factors, and impact. *AAPS J*. 2012;14(4):927–936. doi:10.1208/s12248-012-9407-9

## Drug Design, Development and Therapy

Dovepress

### Publish your work in this journal

Drug Design, Development and Therapy is an international, peer-reviewed open-access journal that spans the spectrum of drug design and development through to clinical applications. Clinical outcomes, patient safety, and programs for the development and effective, safe, and sustained use of medicines are a feature of the journal, which has also

been accepted for indexing on PubMed Central. The manuscript management system is completely online and includes a very quick and fair peer-review system, which is all easy to use. Visit <http://www.dovepress.com/testimonials.php> to read real quotes from published authors.

Submit your manuscript here: <https://www.dovepress.com/drug-design-development-and-therapy-journal>