

# The role of eye size in its pressure and motility

Harry H Mark

Yale-New Haven Hospital, New Haven,  
CT, USA

**Abstract:** A theoretical model demonstrates the influence of the globe's size on the effects of its intraocular pressure (IOP) and on its motility. Large globes seem more susceptible to the damaging consequences of elevated IOP, and move with greater difficulty than small ones. Routine measurement of axial length (AxL) may accordingly enhance precision in the diagnosis and management of glaucoma and strabismus.

**Keywords:** axial length, glaucoma, intraocular pressure, motility, strabismus

## Introduction

As instruments for estimating the globe's size by measuring its axial length (AxL), mostly by ultrasonography, have become more readily available and user friendly (Kushner 2006), it seemed beneficial to briefly explore their utility in the diagnosis and treatment of glaucoma and strabismus with the aim of promoting their routine employment on the way to enhancing quality of care. Size being a geometrical entity, and pressure and motility being physical ones, the following meta-analysis focuses mainly on these disciplines as a starting point and foundation for ultimate clinical application, recognizing full well the limitation of physical models representing complex biological events.

## Terms and definitions

*Axial length* denotes here the linear distance clinically measured from the anterior apex of the cornea to the anterior surface of the opposite retina. Addition of the thickness of the retina and sclera renders the actual geometrical distance about 1–1.5 mm longer, but because of the higher curvature of the cornea the average external diameter of the entire sphere is about 0.5 mm shorter than this. For purposes of physical analysis we accept Duke-Elder (1973, p. 97–99): “On the whole it [the eye] is approximately spherical except in the higher degrees of axial myopia when the sagittal diameter is greatest.” Only the principal forces, and ocular movements in abstract horizontal and vertical meridians, are here considered.

*Acrophthalmos* means here an abnormally long globe, similar to *acrocephalos* (long head) or *acromphalos* (long navel). *Brachomphalos* is a short globe, similar to *brachycephalos* and *brachydont* (short tooth). These terms, measured in millimeters, replace here *myopia* and *hyperopia* which were often used to designate the globe's size, because the latter are measured in optical units of diopters, and do not always relate to size, as Priestly Smith said (1891, p. 122): “Small eyes are not necessarily hypermetropic, and hypermetropic eyes are not necessarily small.” For instance, the terms “Myopic disc” or “Myopic degeneration with retinal detachment” actually referred to physically long globes rather than near-sighted ones (Soheilian et al 2007), while Hyperopia as a risk factor in angle closure (Lowe 1969), or in esodeviation, implied short globes. Furthermore, studies that related glaucoma to “myopia” did not usually distinguish between refractive myopia and axial myopia, an important determinant of the tonometric pressure reading in these two forms (Mitchell et al 1999; Grodum et al 2001).

Correspondence: Harry H Mark  
Yale-New Haven Hospital, 20 York St,  
New Haven, CT, USA  
Tel +1 203 234 2212  
Email iimd@aol.com

Intraocular pressure (IOP) is here given in ‘units’ instead of the wishful ‘mm Hg’ because the clinical tonometric measurements are not direct manometric ones but merely estimates which vary according to the instrument used and to the globe’s physical structure. Precise language is of relevance when communicating clinical or other precise data (Crooke 1981).

## Intraocular pressure

The newborn’s globe is soft and small, growing larger as its IOP increases with the beginning of aqueous humor production (Kinsey 1945). Some have therefore seen the IOP as the impetus to the globe’s growth (similar to an inflating balloon) or to its excessive growth that leads to axial myopia (Barraquer 1971; Graul et al 2002). With increased volume the globe’s coats also become thinner.

By definition, pressure ( $P$ ) is directly proportional to its generating force ( $F$ ) and inversely proportional to the surface area ( $A$ ) to which it is applied perpendicularly:  $P = F/A$ . Goldmann chose for his tonometer a constant area of applanation where resistance of the average cornea to the applanating force was counteracted by the attractive force of the average tear film. Nevertheless, the force needed to applanate the flatter area of a large globe is smaller than the one needed for the steeper cornea of a small globe, where the volume displaced is also relatively larger (Figure 1), (Mark 1973).

Laplace’s equation applies these circumstances specifically to elastic spheres, such as the growing globe:  $P = 2T/r$ , where  $T$  denotes the tangential (not perpendicular) shearing stress on the surface, and  $r$  stands for the radius, that is, the size of the sphere (Szcudlowski 1979; Cahane and Bartov

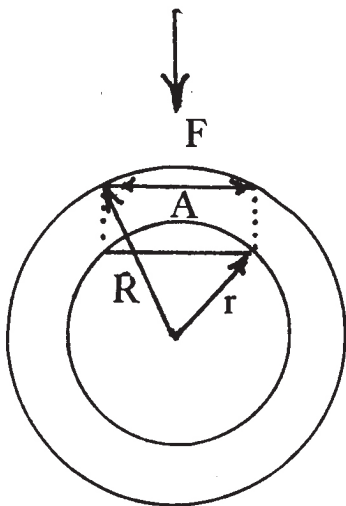
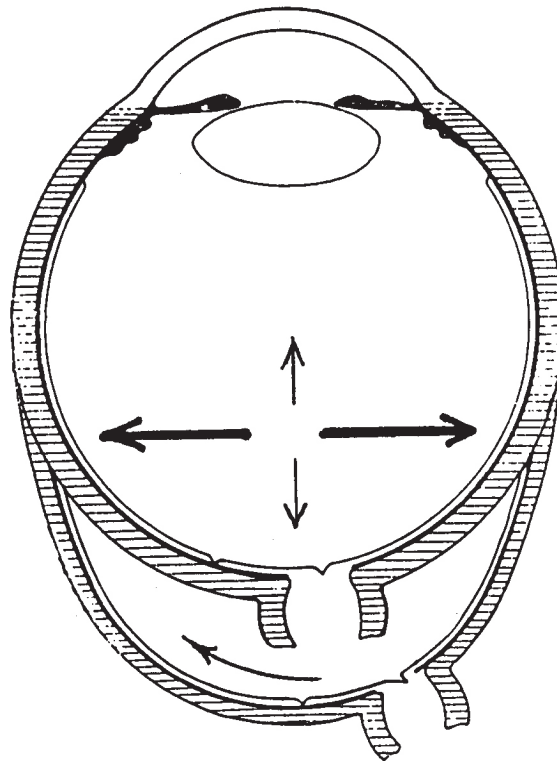

**Figure 1** A smaller force ( $F$ ) is needed to applanate the same area ( $A$ ) in a larger globe ( $R$ ) than a smaller one ( $r$ ).

1992). It follows that for a given pressure  $P$ , its effect on stretching the sclera or retina is greater in a large globe [ $2T = Pr$ ] than a small one, whereas at the same time the perpendicularly applied counter-pressure diminishes.

When Jonas Friedenwald (1937) began researching calibration of impression tonometers (Schiotz) he introduced an equation for ‘scleral rigidity’ where the tonometric reading was inversely proportional to ocular volume, the larger the globe the lower the reading on the tonometer for the same intra-ocular force (Weekers and Grieten 1964). The value of the coefficient itself was found to be considerably reduced in high axial myopia (acrophthalmia) (Draeger 1966). Lower tonometric readings in high volume globes were then discovered also with the applanation method (Leighton 1974). In 513 adult eyes we found a 0.29 unit (“mmHg”) decrease in tonometric reading for every one millimeter increase in axial length, and the 30 longest eyes were over 1 unit softer than the 30 shortest ones (Mark et al 2002).

When pressure in a container of any shape is increased, it assumes the form of a sphere because a sphere contains the maximum volume under the minimum surface area. Therefore, as the IOP in an elongated ellipsoid globe is directed towards forming it into a sphere, it is more effective on the lateral walls than on the anterior-posterior axis (Figure 2); it thus



**Figure 2** Intraocular forces in an elongated globe act further back and are directed more sideways.

stretches the retina in the fundus, as manifested by the myopic (acrophthalmic) cup and crescent (Curtin and Karlin 1971) and distorted brightness distribution (Westheimer 1968). For the same reason it is also easier to indent or applanate an ellipsoid shape, where there is room for expansion, than an already spherical one (Mark 2002). Acrophthalmic globes are in this manner exposed to triple jeopardy of damage due to increased IOP: 1.) According to Laplace the force of stretch on the surface is higher in larger globes. 2.) It is also higher in elongated globes. 3.) The tonometric reading is deceptively low. All this, not counting the as yet in vivo unmeasurable malleability or elasticity of the ocular coats. The fact that increased IOP was the cause of the glaucomatous visual-field defect was convincingly shown experimentally (Gafner and Goldmann 1955).

On the other hand, smaller and shorter globes are at risk for angle-closure and acute glaucoma (Lowe 1969). Our study confirmed that the globes of women were over one millimeter shorter than those of men, and women are well known to be affected by acute angle-closure more often than men.

Knowledge of AxL may thus clinically alert us to the potential for angle closure, suggesting provocative tests or peripheral iridotomy in short globes. Their higher tonometric record may partially explain “ocular hypertension”. Large globes caution us to be vigilant to visual-field loss caused by deceptively low tonometric readings (“low/normal tension glaucoma”). Additional in vivo data of scleral thickness promises to further our knowledge on the effect of IOP and its measurement.

## Ocular motility

“Near-sighted eyes often have limited motility”, said Helmholtz, who gave his own horizontal range of motion as  $100^\circ$  and vertically  $90^\circ$ . Having mentioned earlier that myopic eyes are longer, he must have meant acrophthalmic eyes rather than refractive “myopes” (Helmholtz 1896). Southall called them “sluggish” (Southall 1937). This motility deficit is somewhat ameliorated by the enlarged visual-field due to the prismatic effect of corrective concave glasses (but not contact-lenses).

In order for a large globe to rotate a certain angle  $\beta$  (Figure 3, top) its surface at A is moved a certain distance AB (The small amounts under consideration here minimize the difference between arc and chord values). However, an equally large displacement on a smaller globe ( $CD = AB$ ) results in a larger angle  $\alpha$  of rotation ( $\alpha > \beta$ ). Conversely, when both globes need rotate an equal angle (say  $\beta$ ) the surface of the larger one moves a longer distance than the

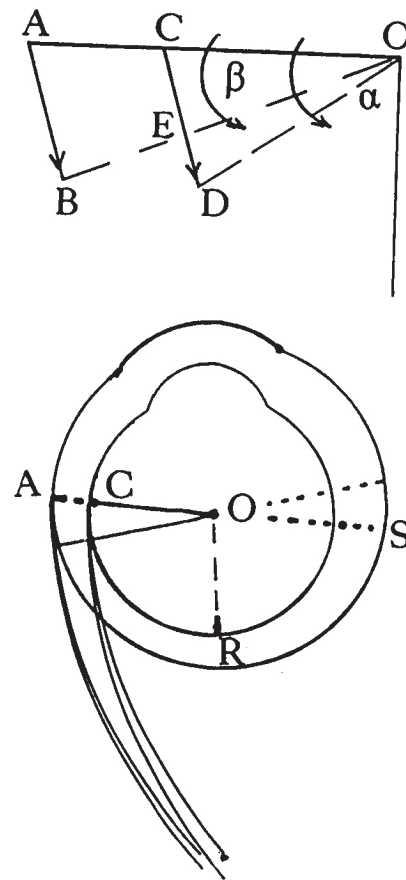
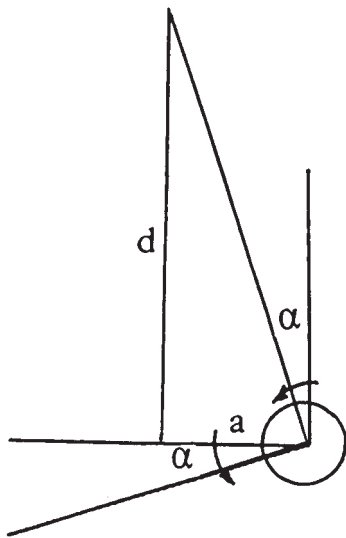

**Figure 3** Schematic representation of moving forces acting on the surface of globes of different size.

smaller ( $AB > CE$ ). The angle of rotation is proportional to the distance that the end-point A or C is moved and to the length of the radius OA or OC, where  $AB/OA = \tan \beta$ . That is, in order to rotate a globe a given angle, its surface must move the farther the longer its radius (AxL, size).

We deal here with basic kinematics rather than the more complex dynamics. There, Archimedes' principle of the lever would also apply, where for equal displacements a stronger force is required at the end of a shorter lever OC than a longer one OA. The effect of the rotational force depends therefore not only on the force of the muscle's contraction and its length but also on the length of the rotated arm – the globe's size (Gillies 1984).

A numeric example may illustrate the theoretical principle. In order to focus at a normal reading distance (d) of say 13" (330 mm), each eye separated by a normal papillary distance of 60 mm (2a) must rotate inward at an angle  $\alpha$  of about  $5^\circ$  (Figure 4):  $a/d = 30/330 = 0.09$ ;  $\tan 0.09 = 5^\circ$ . In order for small globes with a radius of say 11 mm (AxL about ~22 mm) to converge this amount, their medial surfaces at C must move backwards almost 1 mm



**Figure 4** Convergence of the right eye (seen from above).

(CE, Figure 3) [ $CE = 11 \times \tan 5^\circ = 1$ ]. This surface of larger globes, with a radius of say 16 mm (AxL  $\sim 32$ ), must recede approximately 1.5 mm to achieve the same result [ $AB = 16 \times \tan 5^\circ = 1.5$ ], an increase of almost 50%. The opposite side of the globes (at S) must of course advance in the opposite (forward) direction.

When converging to a given near point, a pair of large globes must move farther than smaller ones, or, the stimulus for their convergence must be stronger (assuming equally strong muscles). With equal stimuli, the large eyes (often myopic) will show convergence insufficiency, a common clinical occurrence. For the same reason, small globes (often hyperopic) may exhibit excessive convergence at near, or esophoria. In cases of significant disparity in size of the same pair (“anisometropia”) the smaller eye may overshoot its target, or the larger one will be deficient, solely by dint of their different sizes, no matter what their refractive or accommodative status. Recognizing at the same time that the accuracy of focusing at near depends on a number of other hard to measure and complex psychophysical factors of space perception, aside from simple mechanical and optical ones (Mark 1962).

The clinical applicability of these principles to surgery, which is more an art than science, has been well covered in the literature (Gillies 1982; Kushner and Vrabec 1987; Kushner 1993). It is limited by the complex anatomical circumstances and functional variations (Miller 1989). Furthermore, in pediatric patients AxL measurements are difficult and the globe grows with age. Therefore “Experienced surgeons will establish their own ‘tables’ for the amount they will recess or resect a muscle for a certain measured deviation” (Wagner 2005). Nevertheless, “We agree with

Kushner et al that despite the approximation involved, the use of A scan is superior to other methods of estimating the amount of extraocular muscle surgery required” (Gillies 1991). “A statistically highly significant negative correlation was found between the axial length and the response to strabismus surgery” (Krzizok 1994), that is, the larger the globe the smaller the response to the same surgery.

Suppose one wished to straighten an eye diagnosed with esotropia of 20 prism diopters ( $\sim 10^\circ$ ). If its AxL were about 22 mm, the medial rectus ought to be theoretically recessed 2 mm, and the lateral advanced (or shortened) 2 mm. If, however, AxL was 32 mm, the displacement of the insertions must measure almost 3 mm in order to achieve the same effect, for 2 mm of surgery will result in under correction.

In conclusion, I have tried to impress upon the reader the significant influence of globe size, measured by its axial length, on the effects and measurement of its intraocular pressure and on its motility. The geometrical and physical models serve as simplified skeletons upon which the complex biological components of anatomy, neurology, and biochemistry may then be fleshed. Future statistical data on the relation of AxL to eso and exo deviation, in addition to the customary refractive data, will be helpful. So may be in vivo data on scleral thickness. At present, the routine addition to our clinical armamentarium of measurable AxL data promises to enhance the quality of our diagnosis and management of glaucoma and of strabismus.

## References

- Barraquer JI, Varas JM Jr. 1971. Annotations concerning the relation of forces and pressure in eyes during physical growth. *Ann Ophthalmol*, 3:425–7.
- Cahane M, Bartov E. 1992. Axial length and scleral thickness effect on susceptibility to glaucomatous damage: a theoretical model implementing Laplace’s law. *Ophthalmic Res*, 24:280–4.
- Crooke CP. 1981. Communication in ophthalmology. *Trans Ophthalmol Soc UK*, 102:409–21.
- Curtin BJ, Karlin BD. 1971. Axial length measurements and fundus changes of the myopic eye. *Am J Ophthalmol*, 71:42–53.
- Draeger J. 1966. Tonometry. New York: Hafner Publishing Co.
- Duke-Elder S. 1973. The centre of rotation. In: *System of Ophthalmology*, vol 6, St Louis: CV Mosby, pp 97–9.
- Friedenwald JS. 1937. Tonometer calibration. *Am J Ophthalmol*, 20:985–1024.
- Gafner FH, Goldmann H. 1955. Experimentelle Untersuchungen über Zusammenhang von Augendrucksteigerung und Gesichtsfeldschädigung. *Ophthalmologica*, 130:357–61.
- Gillies WE, McIndoe A. 1982. The use of ultrasonography in determining the amount of extraocular muscle surgery in strabismus. *Aus J Ophthalmol*, 10:191–4.
- Gillies WE, Hughes A. 1984. Results in 50 cases of strabismus after graduated surgery designed by A scan ultrasonography. *Br J Ophthalmol*, 68:790–5.
- Gillies WE, Brooks AMV. 1991. Strabismus surgery landmarks and axial length. *Ophthalmology*, 98:1755.

- Graul TA, Kim CS, Alward WL, et al. 2002. Progressive axial myopia in a juvenile patient with traumatic glaucoma. *Am J Ophthalmol*, 133:700–2.
- Grodum K, Heijl A, Bengtsson B. 2001. Refractive error and glaucoma. *Acta Ophthalmol Scand*, 79:560–6.
- Helmholtz H. 1896. *Handbuch der Physiologischen Optik*. 2nd ed. Hamburg: Voss, p 615.
- Kinsey VA. 1945. Development of secretory function of ciliary body. *Arch Ophthalmol*, 34:415–8.
- Krzizok T, Graf M, Kaufmann H. 1994. Effect of bulbus length on reduction of squint angle after suture fixation. *Ophthalmologe*, 91:68–76.
- Kushner B, Fisher M, Lucchese N, Morton G. 1993. Factors influencing response to strabismus surgery. *Arch Ophthalmol*, 111:75–9.
- Kushner BJ, Lucchese NJ, Morton GV. 1991. Variation in axial length and anatomical landmarks in strabismus patients. *Ophthalmology*, 98:400–6.
- Kushner BJ. 2006. Perspective on strabismus. *Arch Ophthalmol*, 124:1321–6.
- Kushner BJ, Vrabec M. 1987. Theoretical effects of surgery on length tension relationships in extraocular muscles. *J Pediatric Ophthalmol*, 24:126–31.
- Leighton DA. 1974. Der modifizierende Einfluss der Augapfelgröße bei Klaukomen. *Klin Monatsbl Augenheilk*, 164:475–8.
- Lowe RF. 1969. Corneal radius and ocular correlations: in normal eyes and eyes with angle-closure glaucoma. *Am J Ophthalmol*, 67:864–8.
- Leydhecker W. 1960. Statistisch oder individuell “normal”. In: *Glaukom*. Berlin: Springer.
- Mark HH. 1973. Corneal curvature in applanation tonometry. *Am J Ophthalmol*, 76:223–4.
- Mark HH, Robins KP, Mark TL. 2002. Axial length in applanation tonometry. *J Cataract Refract Surg*, 28:504–6.
- Mark HH. 2002. Myopia and glaucoma. *Acta Ophthalmol Scand*, 80:230–1.
- Mark HH. 1962. On the accuracy of accommodation. *Br J Ophthalmol*, 66:39–41.
- Miller JM. 1989. Functional anatomy of normal human rectus muscles. *Vision Res*, 29:223–40.
- Mitchell P, Hourihan F, Sandbach J, et al. 1999. The relationship between glaucoma and myopia: the Blue Mountain Eye Study. *Ophthalmology*, 106:2010–5.
- Phillips CI, Quick MC. 1960. Impression tonometry and the effect of eye volume variation. *Br J Ophthalmol*, 44:149–63.
- Smith P. 1891. *On the pathology and treatment of glaucoma*. London: J & A Churchill.
- Soheilian M, Ghaseminejad AK, Yazdani S, et al. 2007. Surgical management of retinal detachment in highly myopic eyes with macular hole. *Ophthalmic Lasers Imaging*, 38:15–22.
- Southall JPC. 1937. *Physiological Optics*. New York: Dover. p 135.
- Szczudlowski K. 1979. Glaucoma hypothesis: Application of the law of Laplace. *Med Hypotheses*, 5:481–6.
- Wagner R. 2005. Surgical management of strabismus. In: *Harley's Pediatric Ophthalmology* 5th ed. Philadelphia: Lippincott Williams & Wilkins, pp 197–9.
- Weekers R, Grieten J. 1964. Coefficient de rigidité ou coefficient de capacité oculaire? *Ophthalmologica*, 147:67–73.
- Westheimer G. 1968. Entopic visualization of Stiles-Crawford effect. *Arch Ophthalmol*, 79:584–8.

